

# BRAVO GROUPS - COMPACT

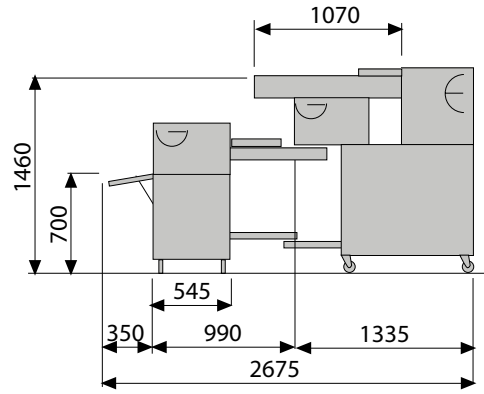

- St/st construction (frame and carters)
- Strong aluminium shoulders 15 mm thick grant stability and precision to the divider and to the moulders
- Computer touch screen 250 programs with automatic control of the weight and of the production per hour (only for touch-screen version)
- 4 Cylinders divider, adjustable sheeting thickness (6 - 20 mm) and electronic speed variation
- Feeding belt capacity 13 kg
- Anti-clogging device to stop feeding belt for a delicate handling of the dough
- 1st moulder type fm-s 4 cylinders 500mm wide
- 2nd moulder (optional) with independent base, placed after the 1st moulder (without telescopic resting belt)
- Device to lift upper belt (the machine can be used as a cylinder)
- 4 Wheels with brake
- St/st moulding table for loaves on wheels (optional)
- Easily interchangeable knives (optional);
- With electronic speed variation for different cutting lengths

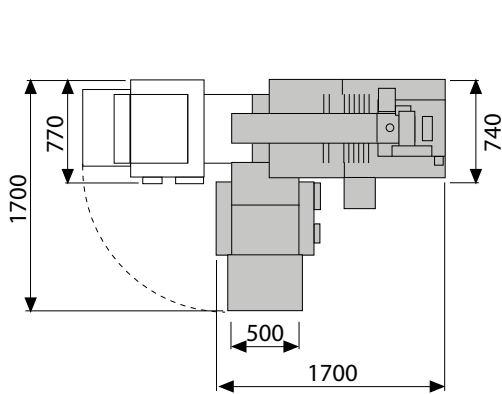
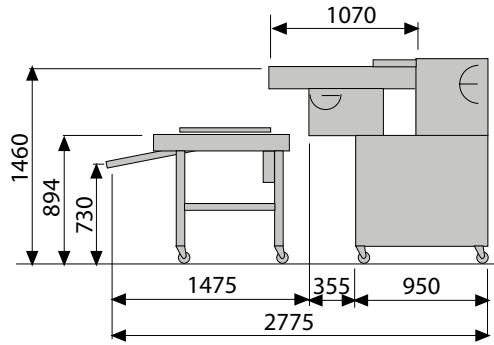
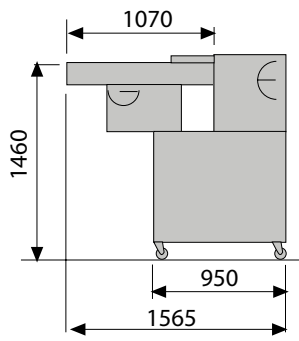

	Knife: number of rows	Weight of dough	Production	Power	Voltage
	n°	g	pezzi/ora	kW	V~/Hz
	1	200÷900	1100÷2100	1,0	400/3N~/50
	2	100÷450	1800÷3800	1,0	400/3N~/50
<b>BRAVO GROUPS - COMPACT</b>	3	50÷300	2700÷4200	1,0	400/3N~/50
	4	35÷100	2700÷4200	1,0	400/3N~/50
	5	25÷60	3600÷4200	1,0	400/3N~/50