

STRATOS OLD STYLE

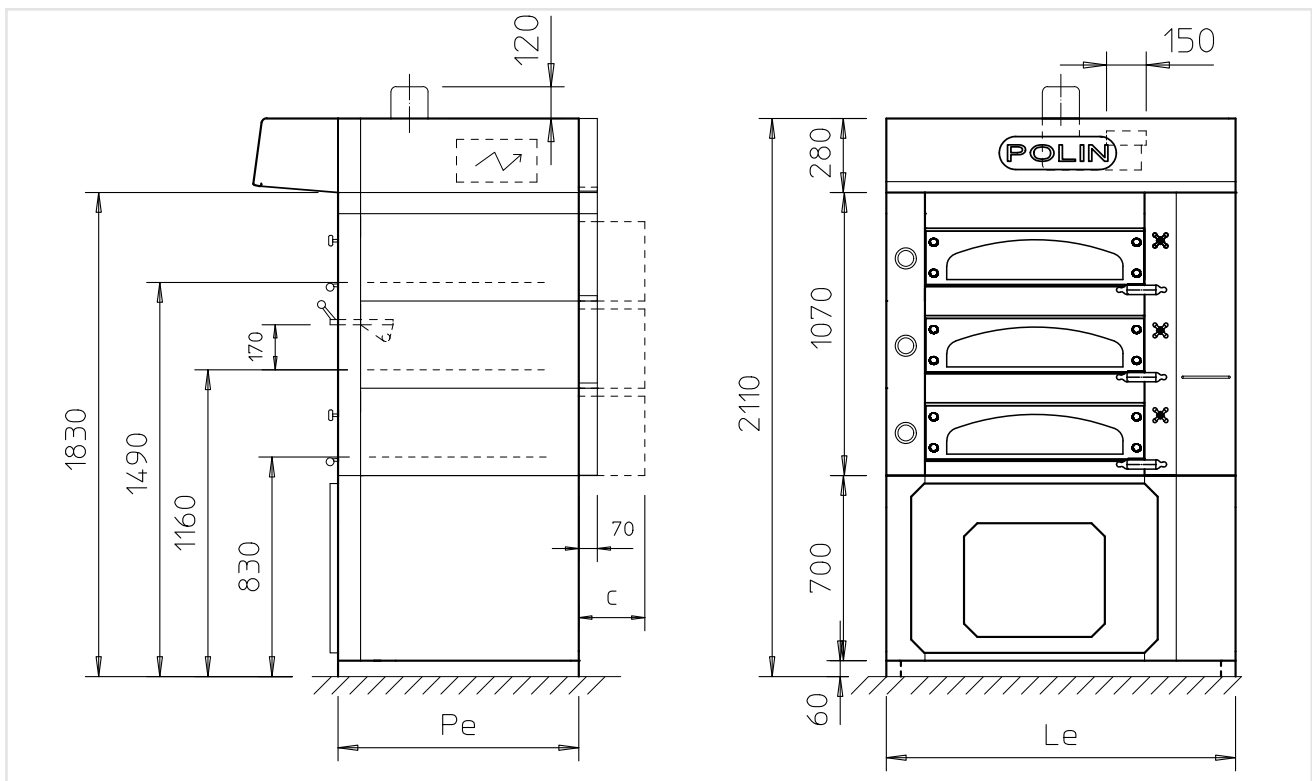



CARATTERISTICHE DI SERIE

- Temperatura massima 380 °C.
- Forno spedito montato (vaporiere escluse)
- N° 3 camere di cottura H18
- Resistenze corazzate in acciaio inox
- Resistenze di bocca indipendenti
- Tastiere digitali "DIGIT 01/E" con funzioni speciali di controllo e risparmio energetico
- Accensione automatica (per ogni camera)
- Termostato di sicurezza di serie per ogni camera
- Cappa con aspiratore a 3 velocità
- Piano di cottura in cemento armato
- Alimentazione standard 400/50/3N

SPECIFICHE FACCIATA "OLD STYLE"

- Facciata in Aisi 304 satinata elettrocolorata nera
- Particolari ottonati
 - cornici termometri
 - impugnature portine
 - ghiera fissaggio cristalli portine
 - manopole scarico vapori camere
 - targa cappa
- Tastiere digitali di controllo camere non in vista (sportello di chiusura)
- Box portalegna
- Termometro indicatore temperatura camera a lancetta
- Cristallo portina con serigrafia nera a volta

STANDARD FEATURES

- *Max temperature 380 °C*
- *Oven shipped completely assembled (steam generators excluded)*
- *Nr. 3 bakings chambers h18*
- *St/st armored heating elements*
- *Independent front elements*
- *"DIGIT 01/E" digital keyboard with special functions for energy saving control*
- *Automatic start (for each deck)*
- *Safety thermostat for each deck*
- *Hood with 3 speeds exhaust fan*
- *"Armored concrete" baking plates*
- *Standard power supply 400/50/3N*

"OLD STYLE" FRONT CHARACTERISTICS

- *Electrocolored front in St/st Aisi 304*
- *Brass plated accessories*
 - *Thermometers with frame*
 - *Chamber doors with handle*
 - *Steam exhaust valve with handle*
 - *Old style plate on the hood-*
- *Hidden digital key-board (Front door)*
- *Box for wood storage*
- *Thermometer with hands*
- *Front cristal with black serigraphy arch shape*

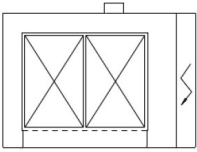
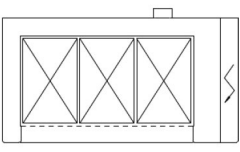
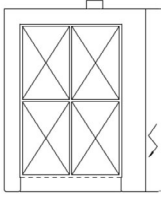
2STA 4060 N°2 40X60	3STA 4060 N°3 40X60	4ST 4060 N°4 40X60
		
n°5 pizze Ø30	n°8 pizze Ø30	n°11 pizze Ø30

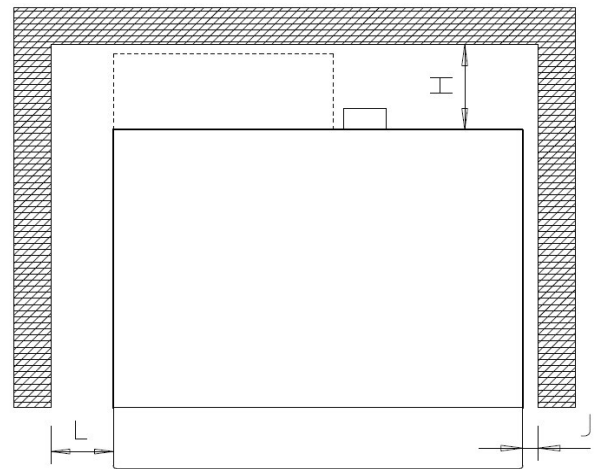
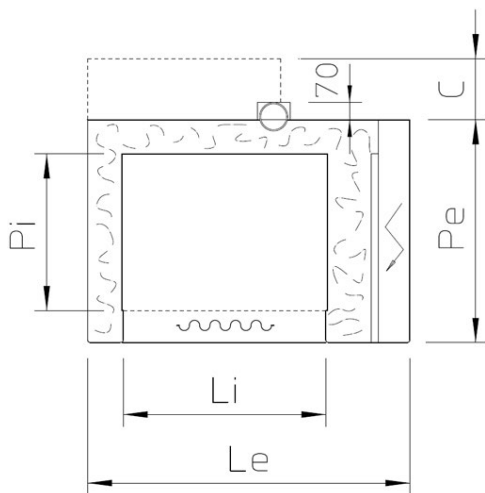

	DISTANZA MINIMA PER UN CORRETTO FUNZIONAMENTO MINIMUM DISTANCE FOR A CORRECT OPERATION		
	H	J	L
FORNO SENZA VAPORIERE OVEN WITHOUT STEAMERS	100	100	80
FORNO CON VAPORIERE OVEN WITH STEAMERS	270		
FORNO 2STL/6040 CON VAPORIERE OVEN 2STL/6040 WITH STEAMERS	340		

DISTANZA MINIMA PER LA MANUTENZIONE MINIMUM DISTANCE FOR MAINTENANCE		
H	J	L
100	600	300
600		

Tipo Camera Chamber type	Le mm	Pe mm	Li mm	PI mm	kg	C mm	kW standard (SENZA VAPORIERE) (without steam generators)	kW Super Power (SENZA VAPORIERE) (without steam generators)	Vaporiera Steamer kW
2STA 4060	1320	910	830	640	800	250	13,6	22,6	1
3STA 4060	1730	910	1240	640	1000	250	19,9	33,4	
4ST 4060	1320	1510	830	1240	1100	250	22	39,7	