

TV DRAGO PELLET AX

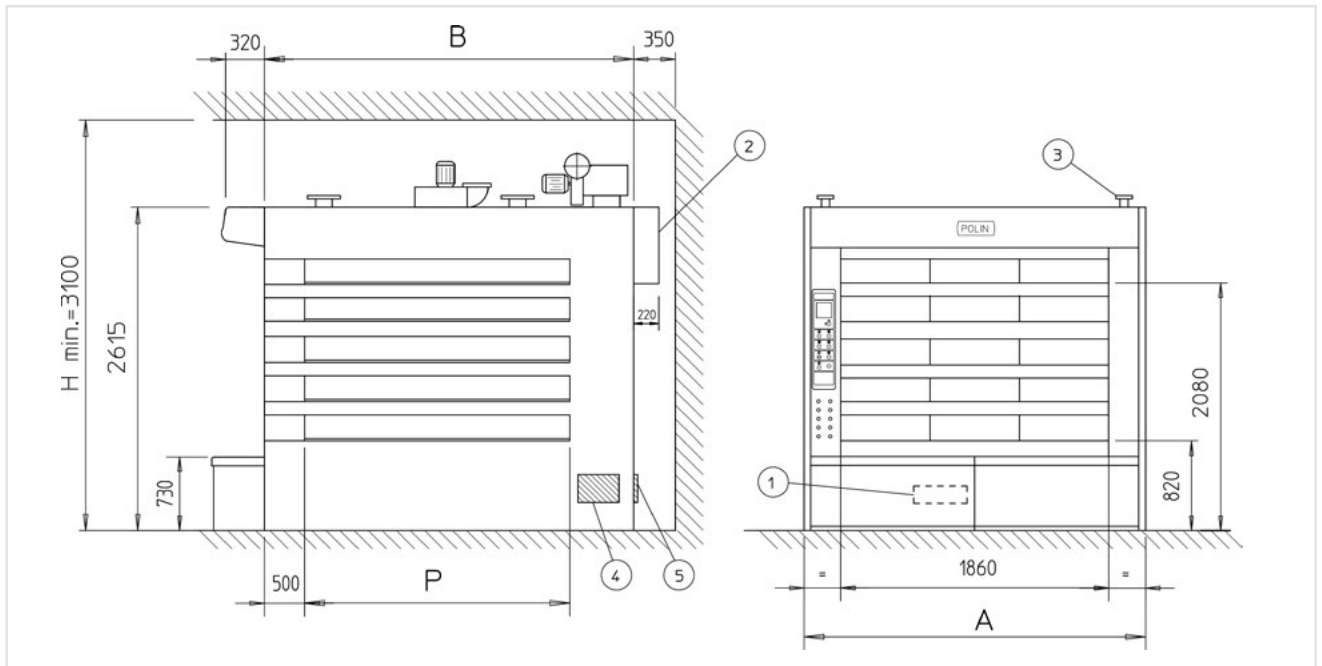

- Deck useful height 22 cm
- Presetting for automatic loading device matching
- N° 1 potentiated steamer for each deck
- Steam generators' control by electrovalve with timer
- Hood with double speed exhaust fan
- Deck decompression discharge valve in the mouth
- N° 1 steam exhaust valve each deck
- Motorised chimney shutter
- It's possible to move controls onto automatic loading device
- Baking plates in "armored concrete"
- Safety thermostat
- Doors with low emission dismountable glass.
- Automatic start
- Aided draught kit
- Available in versions INDUSTRIAL 0.20H and HI CONTROL 0.20H

<i>Power inlet</i>	400/3N~/50
<i>Water inlet</i>	Ø ½" GAS
<i>Steamer drain</i>	Ø 1" GAS
<i>Fuel pipe inlet</i>	-
<i>Steam exhaust output</i>	Ø 250 mm
<i>Fume exhaust output</i>	Ø 250 mm
<i>Frontal door (anti-explosion and cleaning access)</i>	Pos.1
<i>Motorized valves group (optional)</i>	Pos.2
<i>Guide blade plate fixation (optional)</i>	Pos.3
<i>Inspection rear flue cleaning</i>	Pos.4
<i>Side rear cleaning door (Optional burner flame horizontal)</i>	Pos.5



	Chambers	Chambers dimensions		Overall dimension		Installed power		Minimum door width	Weight
		Height	Length	Width	Length	Thermic	Electrical		
	n°	mm	mm	mm	P mm	kcal/h	kW	mm	kg
15,8/186x170-5	5	220	1700	2525	2575	90.000	2,5	650x2200	8900
20,0/186x214-5	5	220	2140	2525	3015	115.000	2,5	650x2200	10700
24,0/186x258-5	5	220	2580	2525	3455	125.000	2,5	650x2200	12500